

ABSTRACT

Go-kart is a simple four-wheeled, small engine, single sealed racing car it is a Go-kart, by definition, no differential. They are usually raced on scaled down tracks, but are sometimes driven as entertainment or as a hobby by non-professionals. Karting is commonly perceived as the stepping stone to the higher and more expensive ranks of motor sports. Kart racing is generally accepted as the most economic form of motor sport available. As a free-time activity, it can be performed by almost anybody and permitting licensed racing for anyone from the age of 8 onwards. Kart racing is usually used as a low-cost and relatively safe way to introduce drivers to motor racing. Many people associate it with young drivers, but adults are also very active in karting. Karting is considered as the first step in any serious racer's career. It can prepare the driver for high-speed wheel-to-wheel racing by helping develop guide reflexes, precision car control and decision-making skills. In addition, it brings an awareness of the various parameters that can be altered to try to improve the competitiveness of the kart that also exist in other forms of motor racing.

KEYWORDS: Fabrication , Equipment's

I. INTRODUCTION

There are many motor sports in the world. Bikes, Cars, Formula one are examples of them. The drivers in these are very professionals and accurate. They can drive it very fast. But there are also motor sports which do not need professional drivers and need no great speed. The vehicles used are also very cheap. Such a motor sport is Go-Karting. They resemble to the formula one cars but it is not as faster as F1 and also cost is very less. The drivers in go-karting are also not professionals. Even children can also drive it. Go-karts have 4 wheels and a small engine. They are widely used in racing in US and also they are getting popular in India.

II. SCOPE OF THE PAPER

Go-Karting is a big craze to the Americans and Europeans. It is initially created in United States in 1950s and used as a way to pass spare time. Gradually it became a big hobby and other countries followed it. In India go-karting is getting ready to make waves. A racing track is ready in Nagpur for go-karting and Chennai is also trying to make one. Indian companies are also producing go-karts in small scale. MRF and Indus motors are the major bodies in karts and they are offering karts between 1 lakh and 3 lakh. But to make go-karts popular, the price must come down. For that, many people are trying to build one under 1 lakh and we had also take up the challenge and make our under 45K. This is a dream come true. A go-kart just under Rs. 45,000/-. So we are sure that our project will have a high demand in the industry and also we are hopping to get orders from the racing guns.

III. PARTS OF A GO – KART

In a Go-Kart, there are mainly six parts. They are

- Chassis
- Engine
- Steering
- Transmission

- Tyres
- Brake
- Electric Starter

- **Chassis**

The chassis is an extremely imported element of the kart, as it must provide, via flex, the equivalent of suspension to give good grip at the front. Karts have no suspension, and are usually no bigger than is needed to mount a seat for the driver and a small engine. Chassis construction is normally of a tubular construction, typically GI with different grades. In this kart, we use GI B class tube with 1" diameter. The chassis support the power unit, power train, the running system etc.



- **Engine**

An engine of a go-kart is usually a small one. About 100-200cc. In this kart, we use a Kinetic Honda Single Cylinder 98cc 2-stroke petrol engine, which produces about 7.7 BHP of power at 5600 rpm. We use 2stroke engine because this is used for racing. So there is no need of mileage. Only power



- **Steering System**

The steering of a go-kart is very sensitive. Because of lack of a differential, a kart's natural direction of travel, forwards, is very difficult to change. However, the two rear wheels are attached by a solid axle, and must therefore move together, so in order to turn, one of the wheels need to skid over the track surface. In this kart we use a special kind of steering system, disc and link mechanism. This mechanism with modification is widely used in racing cars especially formula one cars. In this system, the steering spindle is connected to a disk or plate and this disk is connected to the front two wheels using two links. When steering rotates, the disk also rotates and as a result, the link actuates and the wheel will turn according to the rotation of steering.

- **Transmission**

Transmission means the whole of the mechanism that transmits the power from the engine crankshaft to the rear wheels. In this vehicle, the power from the engine is transmitted to the sprockets using chain, i.e. this is chain drive. The driver sprocket has 12 teeth and driven sprocket has 44 teeth.



Usually go-karts do not have a differential and so we eliminate differential from our vehicle also. And also this go-kart has no clutch and gears because this is automatic transmission. Belt and pulley type CVT is used in this kart. The power from the engine is transmitted to the rear two wheels using chain drive. We use chain drive because it is capable of taking shock loads.

- **Tyers**



For go-karts, wheels and tyres are much smaller than those used on a normal car. The tyres will have increased grip and a hard one. And also it can withstand the high temperature. In this kart, we use tyres having 14" dia for front and 16" dia for rear. This is used for an aerodynamic shape. The tyres must have pressure of at least 18 psi.

- **Brake**



Typically, go-karts will have single rear drum brakes, which are situated on the rear axle. The brake will be capable for stopping the kart running in 40 mph. The pedals actuated by the left leg operate the brakes.

- **Electric Start**

Both Otto cycle and Diesel cycle internal-combustion engines require the pistons to be moving before the ignition phase of the cycle. This means that the engine must be set in motion by an external force before it can power itself. Originally, a hand crank was used to start engines, but it was inconvenient and rather hard work to crank the engine up to speed. It was also highly dangerous. Even though cranks had an overrun mechanism to prevent it, when the engine started, a crank could begin to spin along with the crankshaft. The operator had to pull away immediately, or else risk a broken wrist, or worse. Moreover, as engines evolved, they became larger and compression ratios increased, making hand cranking an increasingly difficult matter.

- **Electric starter**

The modern starter motor is a series-wound direct current electric motor with a solenoid switch mounted on it. When low-current power from the starting battery is applied to the solenoid, usually through a key operated switch, it pushes out a small pinion gear on the starter motor's shaft and meshes it with the ring gear on the flywheel of the engine. The solenoid also closes high current for the starter motor and it starts to run. Once the engine starts, the key-operated switch is opened, a spring in the solenoid assembly pulls the pinion gear away from the ring gear, and the Starter motor stops. Modern starter motors have a "bendix" — a gear and integral freewheel, or overrunning clutch, that enables the flywheel to automatically disengage the pinion gear from the flywheel when the engine starts.



Other than the main parts, the kart also contains some parts such as Mufflers. The muffler we use is Baffle type. In baffle type, the exhaust gas passes through a series of baffles, which causes maximum restriction and hence back pressure. The noise reduction takes place because the length of travel of exhaust gases increases considerably. Other main part is the headlight. Head light is provided at the front of the kart for sane night racing. The requirement of automobiles is that these should illuminate the road ahead at a reasonable distance with sufficient intensity. Also there is a plastic seat in the kart for the driver. The kart is single seated. There is also a bumper in front of the kart.

IV. SYSTEMS USED IN A GO – KART

Like every automobile, go-karts also have various systems. Mainly there are 4 systems in this kart.

- Fuel system
- Ignition system
- Lubrication system
- Cooling system

- **Fuel System**

The purpose of fuel system in SI engines is to store and supply fuel and then to pump this fuel to carburetors. The fuel supply system also prepares the air-fuel mixture for combustion in the cylinder and carries the exhaust gas to the rear of the vehicle. The basic fuel supply system used in the vehicle consists of the following.

- Fuel tank
- Fuel strainer or Fuel filter
- Air cleaner
- Carburetor

Chemistry of Combustion

The type of combustion that takes place in an engine is commonly called Burning. Burning is an example of chemical change. In a chemical change as substance losses those characteristic by which we recognize it and is changed to a new substances with different properties. The petrol is burned in the engine and the products that result no longer resemble petrol. The petrol in the fuel lines differs from the petrol that is drawn into the engine. As it passes through the carburetor and intake manifold and is mixed with aim some of the petrol is changed from liquid to vapour. This process of vaporization is called a physical changed. No new substance is formed since the petrol vapour is still recognized as petrol. Diesel fuel oil and petrol are both mixtures of volatile hydrocarbons compounds of hydrogen and carbon. A compound is a substance that can be separated by chemical means into two or more simpler substances. Hydrogen and carbon are examples of elements. In chemistry an element is defined as a substance, which cannot be separated into simpler substances by chemical action.

Fuel Tank - It is reservoir of fuel oil for an engine. It is kept in and elevated position so that the fuel will flow to the carburetor through the filter by gravity. Our fuel tank has a capacity of 1 litre and there is also a fuel level indicator in it.

Fuel Filter - Dust, particles of dirt or other unwanted particles might be present in the petrol. This petrol should be free from these particles. Therefore, the petrol filter is used.

Air Cleaner - Since the atmospheric air is highly cornices and contains dust and dirt particles, it is allowed to enter the engine intake manifold only through an air cleaner.

Carburetor - The mixture of petrol and air burns in the combustion chamber of the engine. The carburetor is a device to mix the petrol with air in the proper ratio for the purpose of combustion. The quantity of petrol and air can be indifferent ratios. The quantity of petrol can sometimes be more and sometimes less. The speed of the engine changes according to the richness of the petrol in the mixture.

- **Ignition System**

The ignition system used for small two-stroke engine is flywheel magneto type. The advantage of this system is that it is set combined. The flywheel magneto is basically used only for a single cylinder engine though ones suitable for multi-cylinder engine have also been developed. The principles of this type of ignition can be easily understood with following description.

Magneto Generator

The ignition magnet of a magneto generator, which produces alternating electrical impulses in a low-tension armature winding or coil. At an appropriate moment the circuit through the winding is broken by means of an interrupter, which forms an integrate part of the magneto. A condenser connected across the breaker assures rapid cessation of the primary current, and this results in the induction of a high tension impulse in a fine wire secondary winding, which either surrounds the primary winding or is surrounded by it, both being wound on a magnetic coil. An advantage of the magneto is its self-contained character. All the demands of the system are in on compact unit from which it is necessary only to run a low-tension cable to the lighting system and high-tension cable to the spark plug.

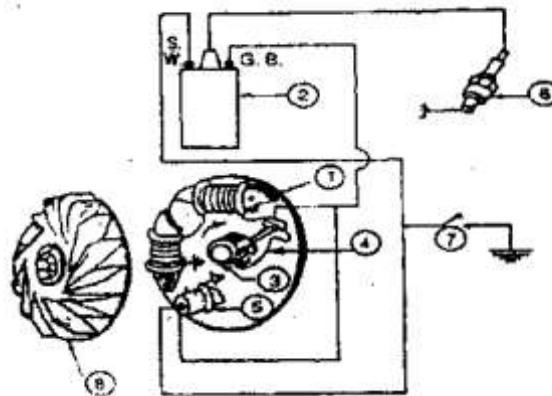

Fly Wheel Magneto (Rotating Magnet Type)

1. Ignition Coil
2. Condenser
3. H. T. Coil
4. Cam
5. C. B. Point
6. Flywheel Magnet
7. Spark Plug
8. Ignition Switch

Figure shows the different views of a single cylinder design of flywheel magneto. A small magnet is provided with laminated pole pieces and the assemblies cast in the engine flywheel, which also acts as a cooling fan. In addition to the magnet, the magneto consists of a coil with a w-shaped or three pole laminated core, an interrupter and a condenser, all of these parts being mounted on a base plate or starter plate. The two curved slots in the stator plate permit of adjusting the spark timing. As the poles of the core pass those of the magnet, the magnetic fluxes passes through the coil first in one and then in the opposite direction and alternating electric impulses are induced in it. When the flux has been well established the primary circuit is closed and a moment later when the primary current is at its maximum, the circuit is broken by the interrupter, which is actuated by a cam on the crankshaft. Magnetos also have a device coupled to it so that the timing is advanced as the engine speed increases. This helps in ignition of the charge in the cylinder. The magnetos are either fitted with build-in type of two coils – one ignition coil and the other lighting coil or alternately they have separate ignition coil. These are attached to a starter or fixed plate and terminate in soft-iron pole-pieces closely matching the shape of the flywheel which rotates around them.

Ignition Coil

The coil consists, in fact, of two coils which may be considered as separated electrically, although they are both wound on the same iron core and share a common terminal. One coil, known as the primary, is fed from the battery, and the principle of operation depends upon the fact that, if the supply to this coil is suddenly interrupted, then the voltage is created or induced in the other coil known as the secondary. The voltage in the two coils can be considered for our purpose to be in the same ratio as the number of turns of wire on the two coils, so that by providing relatively few turns on the primary winding, and a very large number on the secondary the necessary, high voltage is obtained.

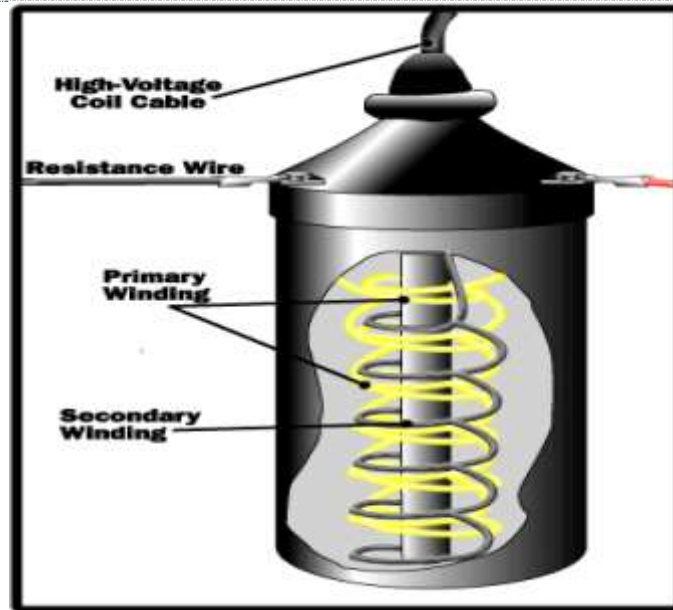

The voltage required to cause a spark between the sparking plug points depends upon both the pressure of the mixture with the cylinder and the gap between the points under average conditions a voltage of the order of 10,000 volts is needed. Earlier it has been stated that the development of the higher voltage in the secondary winding of the ignition coil only occurs when the electricity supplied to the primary winding is suddenly interrupted. This interruption is arranged to take place at the correct time by the contact breaker points.

Spark Plug

An essential part of the ignition system is the provision of electrodes within the engine cylinder, across which the ignition spark can discharge. It is desirable to arrange that these electrodes shall be easily accessible and they are, therefore, mounted on a screwed-in plug. A sparking plug consist essentially of a steel body which bears the earthed electrode, an insulator, and a central rode which forms the other electrode, fed from the distributor. The lower part of the body is threaded to suit a screwed bole provided in the engine, the length of the threaded portion known as the reach and varying with the plug design. The body of the plug seats on to a soft steel washer when it is screwed into the engine. The insulator operates under particularly arduous condition since not only must it withstand the high ignition voltage, but it's lower and is subjected to the full bear of combustion and it is also liable to mechanical shock. At one time, the insulator was mode from porcelain but modern plugs use ceramics based on sintered aluminum oxide.

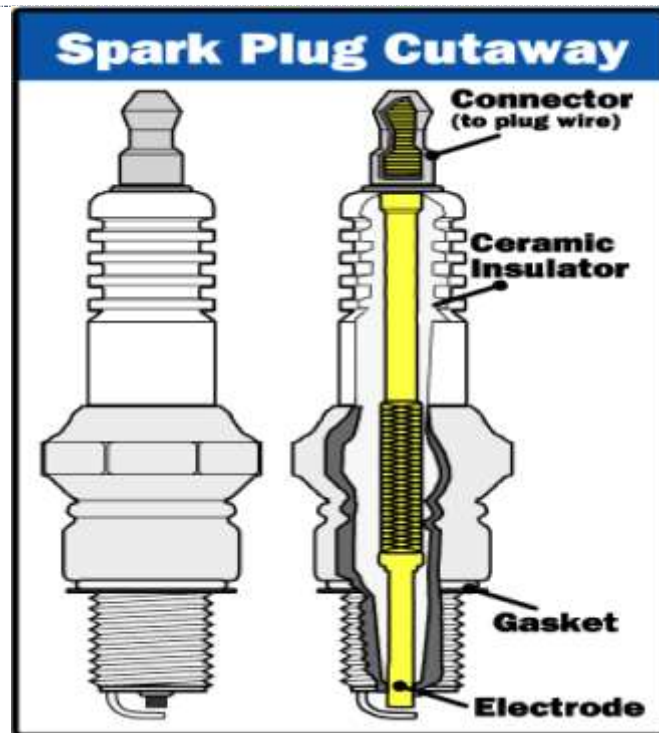

The central electrode is seated into the insulator and is provided with a screwed terminal at the upper exposed end, often shaped to accept a snap-on connector. The tip of the electrode, at which the spark occurs, usually has an insert of heat-resisting metal such as nickel. The ignition voltage is about 25,000 volts and the distance between the central and earthed electrodes is about .022 inch and is adjusted by bending the outer electrode.

- **Lubrication System**

It is a common known that if two rough surfaces are rubbed together, there is a resistance to the motion and heat is generated. In an IC engine surface which rubs together are not tough by normal standards, yet if they are allowed to run in direct contact get one another, the temperature more rise to so high a degree that local melting will occur and the surfaces will slide to seize. It has been shown than even if the surfaces are super finished, seizing will occur unless lubrication is provided. The primary objective of lubrication is to reduce the friction and wear between bearing surface. Lubrication accomplishes this requirement by interposing a film of oil between the sliding surfaces. Other function of lubricating oil in internal combustion engines are, such as the pistons by packing up heat and dissipating it through the crank case and reducing compression losses by acting as a seal between the cylinder walls and piston rings. A lubricant must be able to perform certain task in order to accomplish its purpose satisfactorily. It must possess sufficient viscosity and oiliness to protect mechanical devices of the necessary speeds, pressures and temperatures.

Types of Lubricants

Lubricants are classified in three forms - fluid, semisolid and solid. Fluid oils are used in automobile engine lubrication systems, semi solid oils are used in chassis lubrication. Solid lubrication is done by using graphite and mica. Graphite often with oil to lubricate automobile springs. The use of these types depends upon the work required and the surface to be lubricated.

Splash Lubrication System

The lubrication system used in the engine is splash lubrication system. In this system, oil is splashed over different working parts of an engine. Oil is contained in a through or sump. The big end of connecting rod is provided with a 'spoon or dipper' or 'scoop'. When the piston is at the bottom of its stroke, the big end of connecting rod and crankpin dip into oil. The dipper picks up oil and as the crankshaft rotates, oil is splashed up due to centrifugal force.

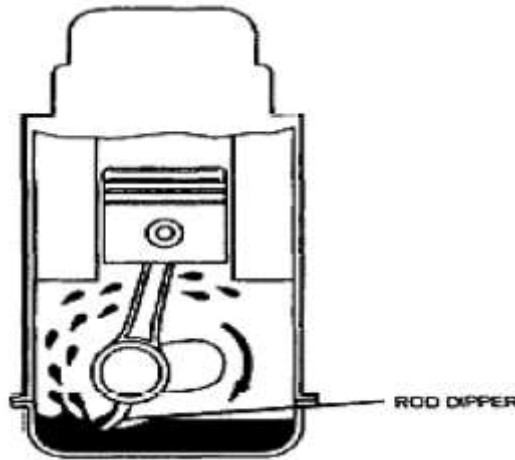

The splashed oil is in the form of a dense mist sprayed into fine particles over surfaces in contact. Small cups are provided close to the bearing of the crankshaft. There are small holes in these cups. The splashed oil fills up these cups from where it is supplied to the bearing. Oil that is splashed onto cylinder walls speeds well when piston reciprocates while the piston rings scarp the oil and get themselves lubricated. Drops of splashed oil drip from the inner side of the piston and lubricate the gudgeon pin and bearings. The crankshaft bearings, valve mechanism and timing gears are also lubricated by splashed oil.

- **Cooling System**

A lot of energy is produced due to the combustion of fuel inside the engine cylinder. Only 30% of heat energy is converted into mechanical work. Out of the remaining heat (about 70%) about 40% is carried away by exhaust gases into the atmosphere. The remaining part of heat energy (about 30%) is absorbed by engine cylinder, cylinder head, piston and engine valves. It causes thermal stress in the engine parts, reduces strength of the piston, decomposition of lubrication oil, burning of valves and it also reduces the volumetric efficiency of the engine. In order to avoid the harmful effects of overheating, it is essential to provide some cooling system for IC Engines. Generally, there are two main types of cooling system. Water cooling and air-cooling. In two stroke petrol engine, air-cooling system is employed.

Air Cooling

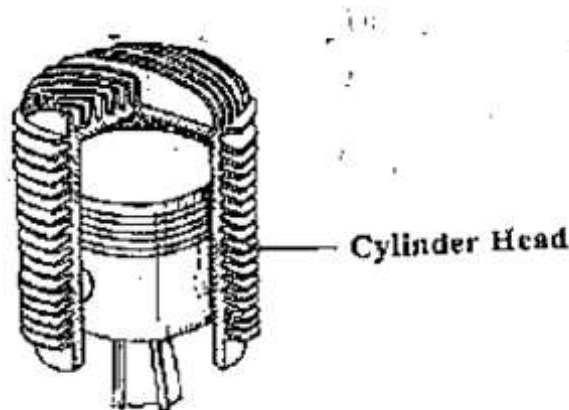

For this cylinder is cast with a number of fins around the cylinder. This type of cylinder is used by motorcycles and scooters and also in go-karts. The air from the atmosphere dashes against these fins and remove the heat from the cylinder.

V. WORKING OF AUTOMATIC TRANSMISSION

This go-kart has no gears and clutches. The transmission we use is not manual, its automatic. For this purpose, we use continuously variable transmission. We use pulley and belt system type CVT. This type of CVT uses

pulleys, typically connected by a metal levered rubber belt. A chain may also be used. A large pulley connected to a smaller pulley with a belt on chain will operate in the same manner as a large gear meshing with a small gear. Typical CVTs have pulleys formed as pairs of opposing cones. Moving the cones in and out has the effect of changing the pulley diameter, since the belt or chain must take a large diameter path when the conical pulleys halves are close together. This motion of the cones can be computer controlled and driven for example, by a servomotor. However in the light weight VDP transmissions used in automatic motor scooters and light motor cycles, the change in pulley diameter is accomplished by a variation, an all mechanical system that uses weights and springs to change the pulley diameters as a function of belt speed. The variable-diameter pulleys are the heart of a CVT. Each pulley is made of two 20-degree cones facing each other. A belt rides in the groove between the two cones. V-belts are preferred if the belt is made of rubber. V-belts get their name from the fact that the belts bear the V-shaped cross-section, which increases the frictional grip of the belt.

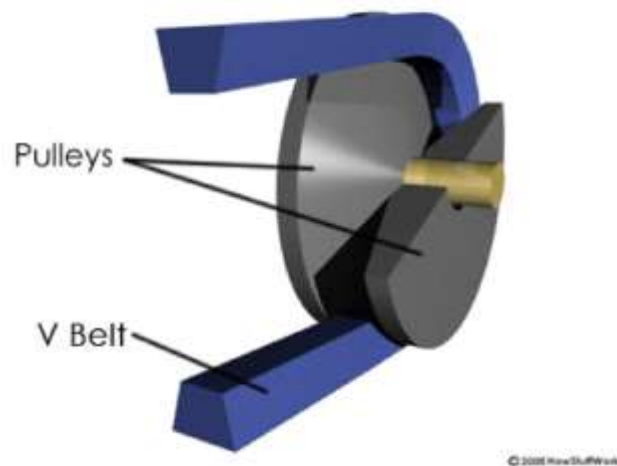

When the two cones of the pulley are far apart (when the diameter increases) the belt rides lower in the groove, and the radius of the belt rides lower in the groove, and the radii of the belt loop going around the pulley get smaller. When the cones are close together (when the diameter decreases) the belt rides tighter in the groove, and the radius of the belt loop going around the pulley gets larger. CVTs may use hydraulic pressure, centrifugal force or spring tension to create the force necessary to adjust the pulley halves. Variable-diameter pulleys must always come in pairs. One of the pulleys, known as the drive pulley (or driving pulley), is connected to the crankshaft of the engine. The driving pulley is also called the input pulley because it is where the energy from the engine enters the transmission. The second pulley is called the driven pulley because the first pulley is turning it. As an output pulley, the driven pulley transfers energy to drive shaft.

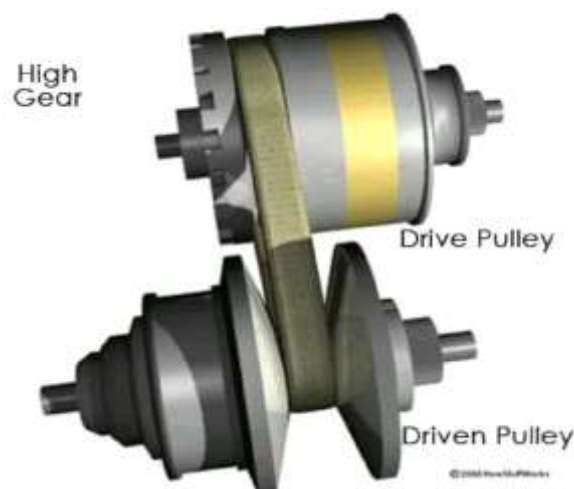

The distance between the centers of the pulleys to where the belt makes contact in the groove is known as the pitch radius. When the pulleys are far apart, the belt rides lower and the pitch radius decreases. When the pulleys are close together, the belt rides higher and the pitch radius increases. The ratio of the pitch radii on the



driving pulley to the pitch radius on the driven pulley determines the gear. When one pulley increases its radius, the other decreases its radius to keep the belt tight as the two pulleys change their radii relative to one another, they create an infinite number of gear ratios-from low to high and everything in between. For example, when the pitch radius is small on the driving pulley and large on the driven pulley, then the rotational speed of the driven pulley decreases resulting in a lower 'gear'. Resulting in a higher 'gear'. Thus in theory, a CVT has an infinite number of 'gears' that it can run through at any time, at any engine or vehicles.

VI. SPECIFICATIONS OF A GO – KART

Engine Displacement (cc)	=	98 cc
No. Of cylinders	=	1
Type of Fuel	=	Petrol
No. Of Strokes	=	2
Maximum power (bhp)	=	7.7 bhp @ 5600 rpm
No. Of gears / variator	=	Variator
Max. Torque	=	1.0 kgm @ 5000 rpm
Overall Length (mm)	=	1650
Height (mm)	=	710
Wheel Base (mm)	=	1270
Ground Clearance (mm)	=	203
Type of Cooling	=	Air cooling
Fuel tank capacity	=	1 litre
Brake	=	Hydraulic

VII. HYDROGEN FUEL

Introduction

Presently, as we noticed the environment are becoming more and more polluted because of increasing carbon dioxide and other impurities an instant action must be taken. This thesis research attempts to overcome these difficulties by showing the pros and cons of implementing “**home gas which runs on fuel cells and the fuel used in it is hydrogen**”. Which employs here hydrogen is used instead of LPG (liquefied petroleum gas) for the purpose of cooking. So, the main term related to the entire thesis work is hydrogen.

Properties Of Hydrogen

Chemical properties

Atomic number	1
Viscosity	0.00892 centipoise, at 25°C
Heat of fusion	58 kJ/kg, at -259°C
Thermal conductivity	0.019 kJ/(ms°C), at 25°C
Heat of vaporization	447 kJ/kg, at -253°C
Electronic shell	1 st
Isotopes	3
Density of gas	0.08987 kg/m ³ at 0.c and 1 atm
Density of solid	858 kg/m ³ at -259°C
Density of liquid	708 kg/m ³ at -253°C
Critical temperature	-240°C
Critical pressure	12.8 atm
Critical density	31.2 kg/m ³
Heat capacity of gas	14.3 kJ/(kg°C), at 25°C
Heat capacity of liquid	8.1 kJ/(kg°C), at -256°C
Heat capacity of solid	2.63 kJ/(kg°C), at -259.8°C

1

Table no. 1: properties of hydrogen

Molecular weight	2.01594
Ionic radius	0.208(-1)nm
Melting point	-259.c
Boiling point	-253.c at 1 atm

➤ Physical properties

- It is tasteless colorless and odorless gas.
- It is the lightest gas.
- Insoluble in water
- It is highly inflammable.
- It burns with blue flame forming water.

Hydrogen as a burnable fuel

- **Energy Content:** Compared with any fuels, H₂ has the maximum energy content per unit mass. The mass of hydrogen is 140.4 MJ/Kg which is about three times larger than that of the gasoline mass i.e. 48.6MJ/Kg. The relative energy sizes of liquid H₂ and gasoline are reversed i.e. (8,491 MJ/m³ vs. 31,150 MJ/ m³), on a volume basis.
- **Limits of flammability:** flammability means how easily something will burn or ignite, producing fire or burning. Hydrogen offers a broader range of flammability the range for H₂ is flammable in 4-75% concentrations, while for gasoline is only from 1-7.6%.
- **Ignition energy** is the least energy necessary to burn an explosive vapor, gas, or dust cloud 0.02 MJ is the ignition energy of H₂ which is very low as compared to that of the gasoline ie.0.24 MJ. This characteristic permits quick explosion for a hydrogen engine, even for a lean mixture.
- **Detonation limits.** When confined, hydrogen can be discharged over a very wide range of concentrations. Similarly, like other fuels, it is very difficult to explode if released into the atmosphere.
- **Auto ignition temperature.** Hydrogen has (585 °C) auto ignition temperature which is considered very higher than compared to other fuels.
- **Flame speed.** Flame velocity of hydrogen is considered higher and is about (1.85 m/s) and of gasoline vapor is (0.42 m/s).
- **Diffusion.** Hydrogen has very great dispersal property. This ability to disperse in air signifies a benefit, as hydrogen leakages can be rapidly dispersed in the environment and hence dangerous conditions are avoided.
- **Density.** Generally hydrogen has very low density and this may cause problems when it is used for transportation purpose; for instance, a identical huge volume is required for the collection of enough hydrogen to offer an suitable driving range.

Production of hydrogen

There are many ways by which hydrogen can be produced. This thesis paper gives a brief description about seven to eight different hydrogen production ways and method. We can be categorized as:

- Way of producing hydrogen from natural gas
 - SMR symbolizes steam methane reforming
 - POX represent partial oxidation
 - ATR signifies auto thermal reforming
- way of obtaining hydrogen from coal
- way of constructing hydrogen from splitting of water
 - electrolysis(water)
 - electrolysis(alkaline)
 - electrolysis of PEM which denote polymer electrolyte membrane

- (high temperature) electrolysis
- photo-electrolysis which is also called photolysis
- photo- biological production which is generally called bio photolysis
 - (high) temperature water decomposition
 - water splitting thermo chemically
- biomass equals to hydrogen
- integrated production (hydrogen)
- dispersed production (hydrogen)
- hydrogen through aluminum

VIII. SPLITTING OF WATER

There are various processes by which hydrogen can be produced from splitting of water. **Electrolysis of pure water:** Generally electrolysis of unpolluted water is a method in which water split into hydrogen and oxygen by the means of electric current.

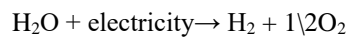

The total energy marginally increases with increasing temperature, whereas the electrical energy decreases. The (water) electrolysis includes the various types of electrolysis they are:

- **Alkaline:** This electrolysis process uses an aqueous potassium hydroxide (KOH) solution as an electrolyte that regularly flows through the electrolytic cells. Alkaline electrolysis is appropriate for stationary applications and generally needed up to 25 bar operating pressure. It has an important operating record in industrial applications and is considered as a developed technology, which also permits remote operation. In alkaline electrolysis cell following reaction take place.

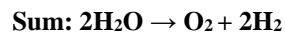
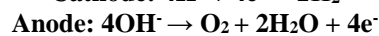
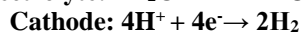

The main components of an alkaline electrolyser are shown in the following fig.

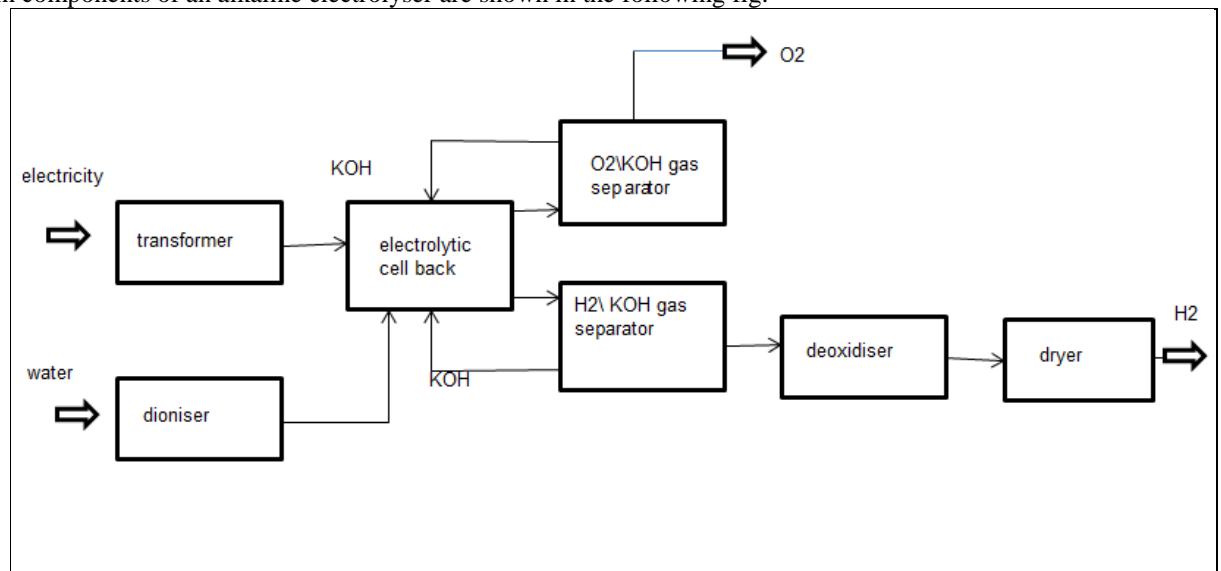
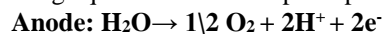

Fig 1: diagram representing process of alkaline electrolysis

The most important challenge for future is to design and create electrolyser components at lower costs with greater efficiency and higher turn-down ratios.

- **Polymer electrolyte membrane:** The following equations show the principle of PEM electrolysis.





PEM electrolysis has a simple design as it does not require any liquid electrolyte. Here the electrolyte is an acidic polymer membrane. The operating pressure is up to several hundred bar of PEM electrolyser. The main advantages of PEM over alkaline electrolyser are:

- ❖ The larger turn down ratio
- ❖ The improved protection due to the absence of KOH electrolytes.
- ❖ A more compact design due to greater densities.
- ❖ And higher operating pressure.

The main disadvantages of PEM are:

- ❖ The limited period of the membranes.
- ❖ High cost
- ❖ Low capacity
- ❖ And poor efficiency

And because of these disadvantages PEM electrolysers are not as developed as alkaline electrolysers. By working in the field of material development and cell stack design, it is predicted that the performance of PEM electrolysers can be enhanced.

- **High temperature:** The phenomena of high temperature fuel cell are considered when we talk about high temperature electrolysis. To split water at 1000°C the electrical energy needed is significantly less than electrolysis at 100°C. This refers that a high temperature electrolyser give high efficiency in contrast to low temperature electrolyser. Solid state electrolyser cell (SOEC) is an example of this technology, which is based on the solid fuel cell (SOFC). The operating pressure is 700 to 1000°C. The electrode reactions are more reversible, and the fuel cell reaction also can more easily be reversed to an electrolysis reaction at this temperature. Presently, efforts are proceeding to develop such system in which electricity consumed by the electrolyser can be reduced by using the heat available from geothermal, solar or natural gas sources and thus helps in reducing the consumption of electricity. Here the main challenge is the materials development and thermo mechanical stress within the fundamental ceramic materials.
- **Photolysis:** Here, a photovoltaic system joined to electrolyser is present. This system gives two outputs.
 - ❖ Electricity from photo voltaic cell
 - ❖ And hydrogen from electrolyser

So the system is considered to be flexible. The process of splitting of water into hydrogen and oxygen by light is known as photo electrolysis of water. This process is considered as an inexpensive process because here solar energy is used instead of electricity. The following figure represents the diagram explaining the principle of photo electrolytic cell.

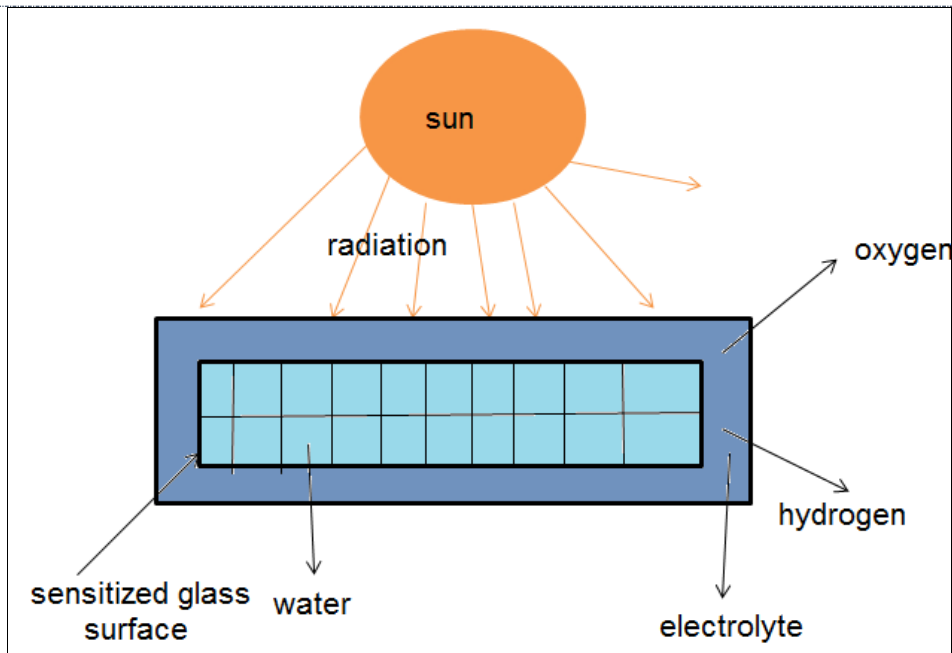

Fig2: principle of photo-electrolytic cell

1.3.4 Bio photolysis: generally, the two steps photosynthesis and hydrogen production are used for producing hydrogen from bio-photolysis. Here, hydrogenases like green algae and cyano- bacteria catalyze the reaction.

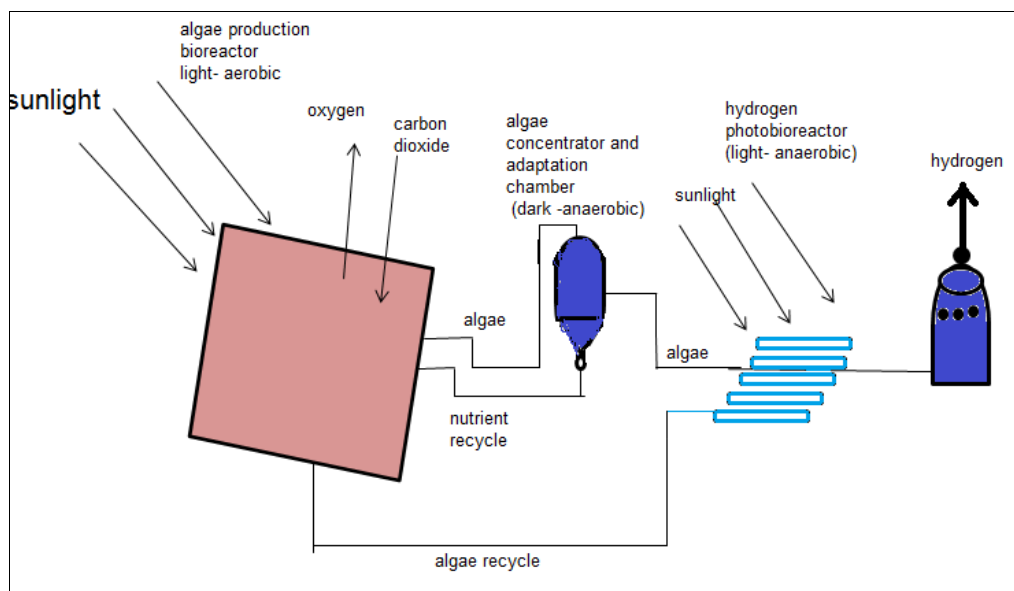
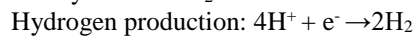
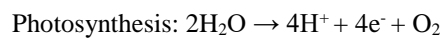

Fig3: principle of photo-biological hydrogen production

- **{High}temperature decomposition**

At about 3000 °C, High-temperature splitting of water occurs. At this temperature, 10% of the water is decayed and the residual 90% can be reused. Other processes for high temperature splitting of water to reduce the temperature are:

- ❖ Thermo-chemical cycles.
- ❖ Hybrid systems coupling electrolytic decomposition and thermal decomposition.
- ❖ Nonstop catalytic corrosion of water with separation through a ceramic membrane.

Efficiencies above 50 % can be estimated for these methods, and could probably lead to a major drop in hydrogen production costs. Materials development for corrosion resistance at high temperatures is the main problem for these high-temperature processes. Design features and protection are also essential for high-temperature processes.

- **Water splitting thermo-chemically**

The conversion of water into hydrogen and oxygen by a series of thermally driven chemical reactions is called “**Thermo-chemical splitting of water**”. This method includes rotations process which is well-known for the previous 35 years. An example of a thermo-chemical process is the iodine/sulphur cycle as shown in following equations:

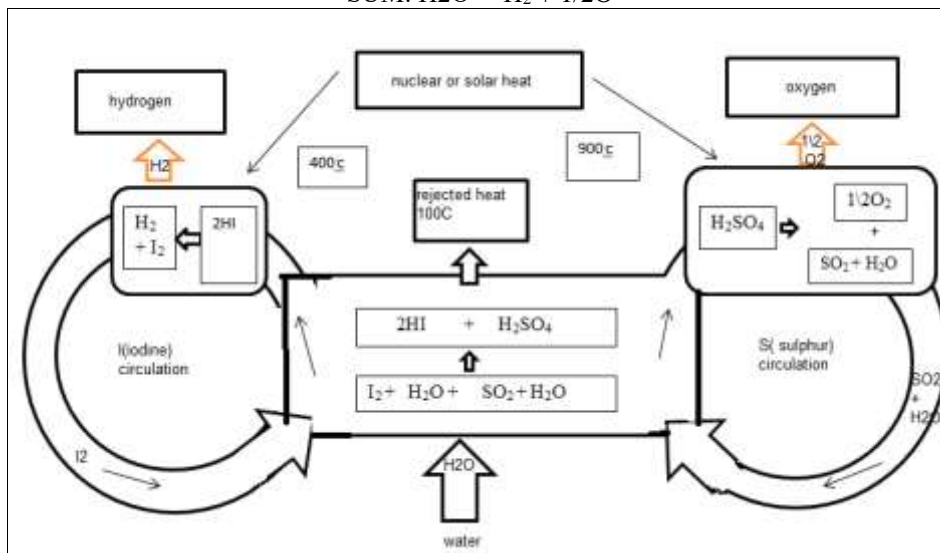
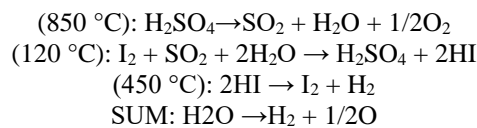
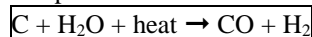

Fig4: Principle drawing of iodine/sulfur thermo-chemical process

1.3.5: BIOMASS = HYDROGEN

A hydrogen-containing gas is generally produced by a similar fashion related to the gasification of coal, in biomass conversion processes. There are no commercial plants to produce hydrogen from biomass. Reaction is this process is:



Now, the ways followed to produce hydrogen from biomass are steam gasification, entrained flow gasification, and other innovative concepts like gasification in splendid dangerous water, use of rotations, or the conversion of intermediates. These concepts can't reach a demonstration phase for hydrogen production. The R&D area shared between H₂ production and biofuels production is Biomass gasification. Pyrolysis and Gasification are assumed as the most capable medium-term technologies for the commercialization of H₂ production from biomass. A classic flow sheet for the production of hydrogen from biomass is shown in the following figure.

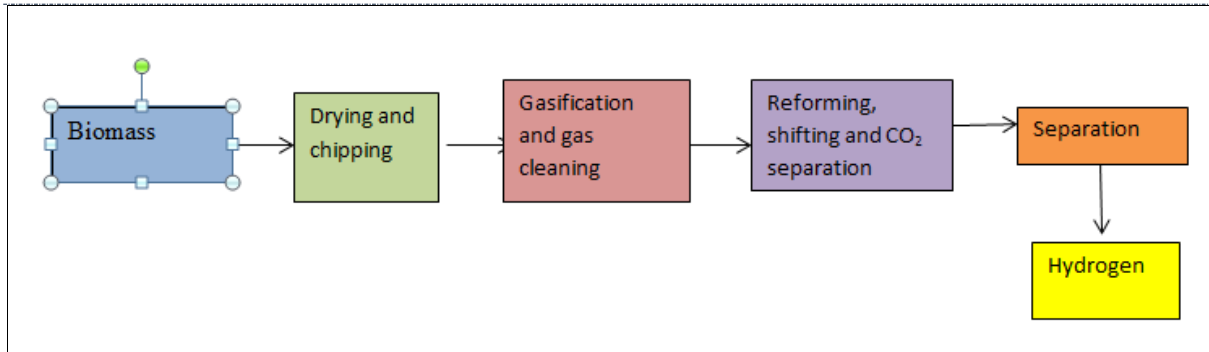

Fig5: production of hydrogen

1.3.6: Centralized h₂ production:

Hydrogen production from all fossil energy sources in large-scale industries can be considered as a profitable technology for engineering purposes. At a large scale Hydrogen production shows the potential for comparatively low component costs, whereas in medium sized plants the hydrogen production cost from natural gas may be cheap towards the cost of large-scale production. Technically and commercially carbon dioxide capture and storage are not established. They require the absorption or separation procedure. It is also of vital importance to raise the plant efficiency, decrease capital costs and develop reliability and operating flexibility. . This involve of the development of catalysts, to separate the (carbon dioxide) CO₂ from the gas mixture, adsorption materials and gas separation membranes for the commercially manufacture and purifying of hydrogen.

In the future, to remove the requirement for capture and storage of CO₂ and increase its tolerances, renewable energy and left-over heat can also be an alternative in the field of centralized hydrogen production.

1.3.7: Distributed H₂ production:

Both water electrolysis and the natural gas processes helps up to a great extent in “Distributed hydrogen construction”. The chief benefit of this method remains that there is no need for the transportation of hydrogen fuel, and so it doesn’t require construction of a new hydrogen infrastructure and hence helps in reducing cost. Distributed production also uses prevailing arrangement, for instance ordinary air or liquid and electrical rule. However, the production costs are greater for the smaller-capacity production facilities, and the efficiencies of production will maybe lower than those of centralized plants. In general, carbon capture and Sequestration are more challenging and expensive in small fossil-fuelled plants. Also, it is suspected that when hydrogen is produced from distributed reformers CO₂ from fossil fuels will be captured and stored.

1.3.8: By aluminium:

In this method, Aluminium reacts with electrolyser like NaOH sodium hydroxide / KOH potassium hydroxide and water, to produce sodium metaaluminate and hydrogen. This process is highly exothermic so coolant is required for the reactor to operate the reaction.

Reaction involved is this in this process is:

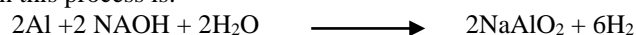
**1.4 Simple fuel cell:**

A simple fuel cell is a method that uses hydrogen as a fuel to yield heat and water. The simple combustion reaction on which **Fuel cell technology** is based is given in following equations.

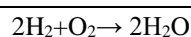

The simple scheme of a fuel cell includes two electrodes on both side of an electrolyte. Hydrogen and oxygen pass above both the electrodes and by means of a chemical reaction, heat, electricity and water are formed. Hydrogen fuel is delivered to the anode, the negative terminal of the fuel cell while oxygen is delivered to the cathode, the positive terminal of the fuel cell. By a chemical reaction, the hydrogen is divided into an electron and a proton. Each takes a unique route to the cathode. The electrons are when attached correctly can harvest electricity for a given load and also are capable of taking a path other than over the electrolyte. The proton

[Prajapati * *et al.*, 6(7): July, 2017]
IC™ Value: 3.00

passes over the electrolyte and both are joined up at the cathode. The, proton, oxygen and electron combine to form the nontoxic byproduct of water. This process is well described in the following fig:

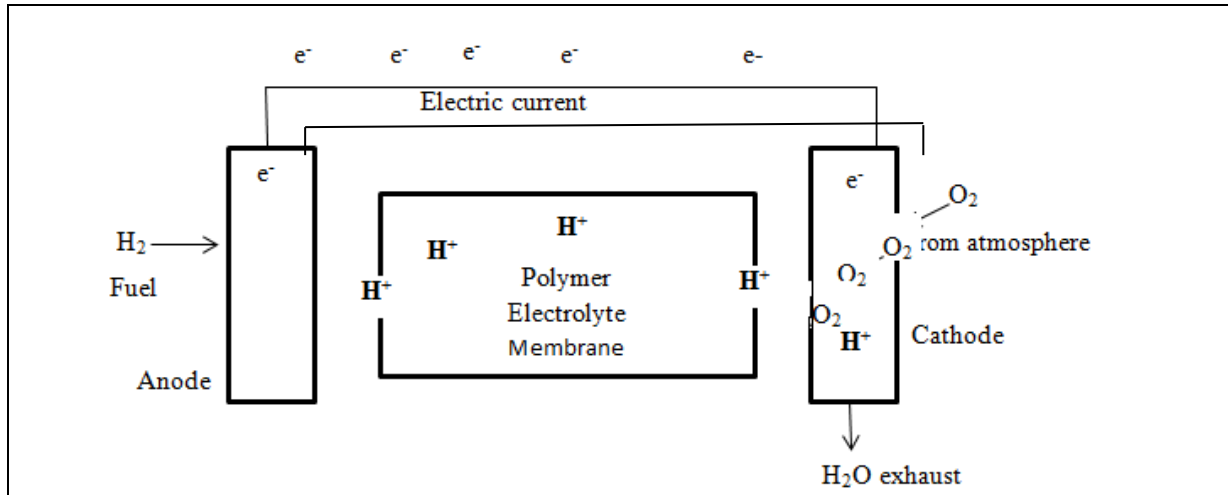

Fig 6: simple fuel cell operation

The hydrogen fuel can be delivered commencing a wide variety of constituents if a fuel improver is added to the fuel cell system. Therefore, as already discussed above hydrogen can be achieved from hydrocarbon fuel such as natural gas or methanol. The fuel cell's means for generating electricity is by a chemical reaction, therefore there are considerably hygienic discharges than from a fuel ignition process.

IX. ITEMS AND APPARATUS USED IN MAKING HYDROGEN FUEL CELL



Metal Cutterbattery



Wiresbattery Clamps



Drill Bit (Hss) Small Clamps



Soldering Wirevernier Calliper



Ro-Cylinderhss Sheet



RO-PIPE

Cylinder Ring



Ro-Cylinder Cap L-Joint



Rubber washer



Teflon tapecutter



Holder distilled water



Wire ties washers



Marker oil with water



Drilling machine



Sheet cutting

X. MEASUREMENTS







XI. CONCLUSION

We have completely added hydrogen as a fuel with petrol in our GO-KART. Hydrogen reduces 25% petrol consumption and increases efficiency of the engine. We are producing 1 lpm (litre per minute) hydrogen for safety of engine, because more than 1 lpm hydrogen can damage the engine. So we have to maintain hydrogen production and intake of hydrogen in engine. The HHO gas in the hydrogen fuel cell is prepared by the electrolysis process by splitting of water. So, the primary source used in the production of HHO gas is water which is well known for its abundance. So fuel cell helps in dealing with one of the major problem by reducing the production cost of hydrogen. Hence by the use of "home gas by hydrogen fuel cell" we can save money up to a great extent. And we also know the hydrogen gas is eco-friendly, thus it is emission free and produces no carbon during the use.

To get a desirable output, we must consider:

- Plate- 2-2.2 volt per plate
- Current- 1 amp per inch² active surface area of the plate.

Plate size = 217.5cm²

Maximum current which can pass in the reactor (with its full efficiency) is

Current = 1 amp.



For 12 volt DC supply, having lamp:

- H₂ output is: 1 LPM
- Output HHO: 60 liters
- H₂: 40.2 liters
- O₂: 19.8 liters in an hour.
- Energy density of H₂ = 130MJ/kg

Density of H₂ = 0.085 gm/l at room temperature.

XII. REFERENCES

- [1] Seda Joseph B. "Drive Train Paper Report August". Paper #1 UPRM Mini Baja 2006-2007. SAE. 2006.
- [2] Gillespie, Thomas D., Fundamentals of Vehicle Dynamics. Warren dale: SAE. 1992.
- [3] Lerner, Preston. "Going Nowhere Fast". Popular Science. November 2006.
- [4] Thompson, Dale. "Ackerman? Anti-Ackerman? Or Parallel Steering?" Racing Car Technology, 2006.
- [5] Reimpell, Jornsen., et all. The Automotive Chassis: Engineering Principles. 2nd ed. Oxford: Butterworth-Heinemann. 2001.
- [6] Smith, Carroll. Racing Chassis and Suspension Design. Warrendale: SAE. 2004.
- [7] Nobels t, Deprez W., Pardon I, Stevens S., Viktorin O, Driesen J, Belmans R, design of a small personal electrical vehicles as an educational project, 11th international power electronics and motion control conference, Riga, Letland, Sept.2-4, 2004
- [8] IOSR Journal of mechanical and civil engineering (IOSR-JMCE)
- [9] WokjeAbrahamse, Michael Keall., Effectiveness of a web-based intervention to encourage carpooling to work: A case study of Wellington, New Zealand Original Research Article Transport Policy, Volume 21, May 2012, Pages 45-51
- [10] UliGolle, Franz Rothlauf, Nils Boysen., Car sequencing versus mixed-model sequencing: A computational study Original Research Article European Journal of Operational Research, Volume 237, Issue 1, 16 August 2014, Pages 50-61
- [11] Peng-Sheng You, Yi-Chih Hsieh., A study on the vehicle size and transfer policy for car rental problems Original Research Article Transportation Research Part E: Logistics and Transportation Review, Volume 64, April 2014, Pages 110-121 14
- [12] IstvánHorváth, Jeroen van Beeck, Bart Merci., Full-scale and reducedscale tests on smoke movement in case of car park fire Original Research Article Fire Safety Journal, Volume 57, April 2013, Pages 35-43
- [13] Suk Jae Jeong, Kyung Sup Kim, JinWon Park., CO2 emissions change from the sales authorization of diesel passenger cars: Korean case study Original Research Article Energy Policy, Volume 37, Issue 7, July 2009, Pages 2630-2638
- [14] SeyedehsanSeyedabrishami, AmirrezaMamdoohi, Ali Barzegar, SajjadHasanpour., Impact of Carpooling on Fuel Saving in Urban Transportation: Case Study of Tehran Original Research Article Procedia - Social and Behavioral Sciences, Volume 54, 4 October 2012, Pages 323-331
- [15] Frances Sprei, StenKarlsson., Energy efficiency versus gains in consumer amenities—An example from new cars sold in Sweden Original Research Article Energy Policy, Volume 53, February 2013, Pages 490-499
- [16] Karl Georg Høyer., The history of alternative fuels in transportation: The case of electric and hybrid cars Original Research Article Utilities Policy, Volume 16, Issue 2, June 2008, Pages 63-71 19
- [17] The history of alternative fuels in transportation: The case of electric and hybrid cars Original Research Article Utilities Policy, Volume 16, Issue 2, June 2008, Pages 63-71 20
- [18] Miao Fu, Aoife Ahern, Andrew Kelly., Regional characteristics and the distribution of car engine sizes: A case study of Ireland Original Research Article Transportation Research Part D: Transport and Environment, Volume 16, Issue 7, October 2011, Pages 509-514.

CITE AN ARTICLE

Prajapati, Sahil , Prateek Yadav, Amit Tiwari, Ajeet Kumar, and Vinay Soni. "ECONOMIC FEASIBILITY OF CRUSHED GRANITE & MARBLE FOR PARTIAL REPLACEMENT OF NATURAL SAND IN M 30 GRADE CONCRETE." *INTERNATIONAL JOURNAL OF ENGINEERING SCIENCES & RESEARCH TECHNOLOGY* 6.7 (2017): 340-65. Web. 15 July 2017.